

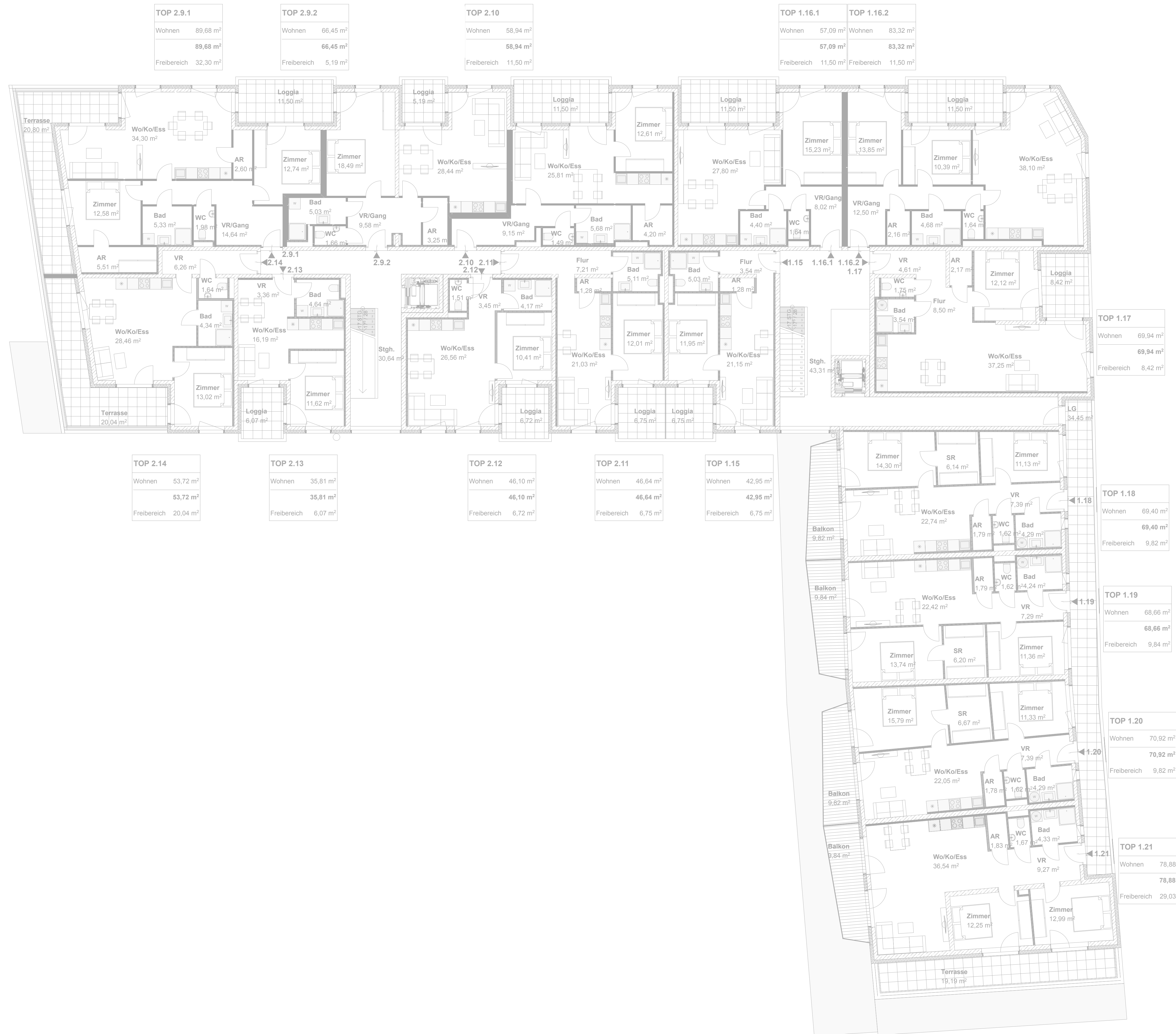

TOP 1.1	TOP 1.2	TOP 1.3	TOP 1.4	TOP 1.5	TOP 1.6
Verkaufen 193,01 m ²	Wohnen 69,40 m ²	Wohnen 68,66 m ²	Wohnen 70,92 m ²	Wohnen 41,72 m ²	Wohnen 80,33 m ²
193,01 m ²	69,40 m ²	68,66 m ²	70,92 m ²	41,72 m ²	80,33 m ²
	Freibereich 19,82 m ²	Freibereich 19,66 m ²	Freibereich 22,32 m ²	Freibereich 12,83 m ²	Freibereich 20,96 m ²





TOP 2.9.1	
Wohnen	89,68 m ²
	89,68 m ²
Freibereich	32,30 m ²

TOP 2.9.2	
Wohnen	66,45 m ²
	66,45 m ²
Freibereich	5,19 m ²

TOP 2.10	
Wohnen	58,94 m ²
	58,94 m ²
Freibereich	11,50 m ²

TOP 1.16.1	
Wohnen	57,09 m ²
	57,09 m ²
Freibereich	11,50 m ²

TOP 1.16.2	
Wohnen	83,32 m ²
	83,32 m ²
Freibereich	11,50 m ²

TOP 2.14	
Wohnen	53,72 m ²
	53,72 m ²
Freibereich	20,04 m ²

TOP 2.13	
Wohnen	35,81 m ²
	35,81 m ²
Freibereich	6,07 m ²

TOP 2.12	
Wohnen	46,10 m ²
	46,10 m ²
Freibereich	6,72 m ²

TOP 2.11	
Wohnen	46,64 m ²
	46,64 m ²
Freibereich	6,75 m ²

TOP 1.15	
Wohnen	42,95 m ²
	42,95 m ²
Freibereich	6,75 m ²

TOP 1.17	
Wohnen	69,94 m ²
	69,94 m ²
Freibereich	8,42 m ²

TOP 1.18	
Wohnen	69,40 m ²
	69,40 m ²
Freibereich	9,82 m ²

TOP 1.19	
Wohnen	68,66 m ²
	68,66 m ²
Freibereich	9,84 m ²

TOP 1.20	
Wohnen	70,92 m ²
	70,92 m ²
Freibereich	9,82 m ²

TOP 1.21	
Wohnen	78,88 m ²
	78,88 m ²
Freibereich	29,03 m ²





TOP 1.31

Wohnen	85,12 m ²
	85,12 m ²
Freibereich	143,72 m ²

TOP 1.32

Wohnen	81,00 m ²
	81,00 m ²
Freibereich	68,72 m ²

TOP 1.33

Wohnen	74,92 m ²
	74,92 m ²
Freibereich	89,35 m ²

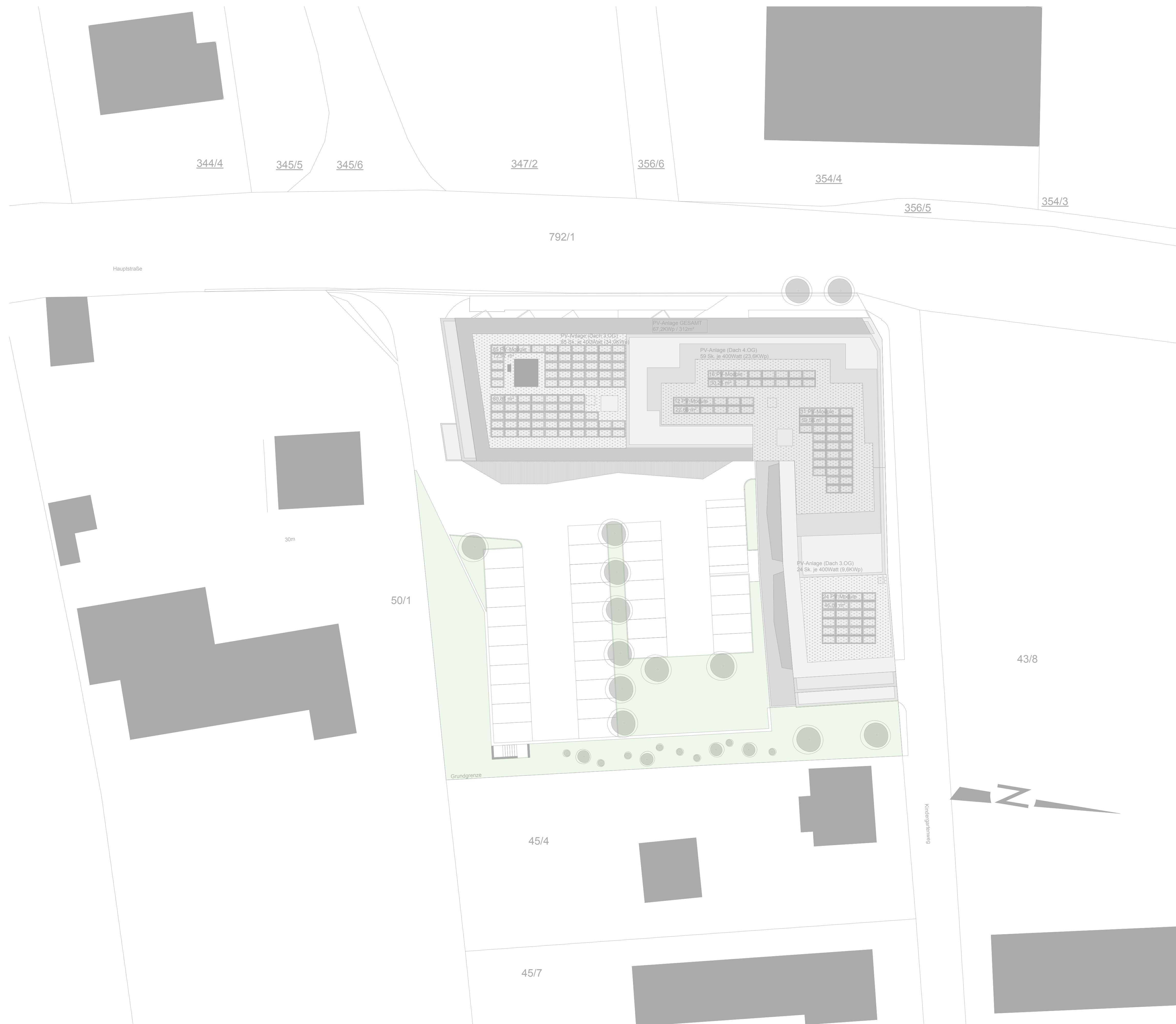

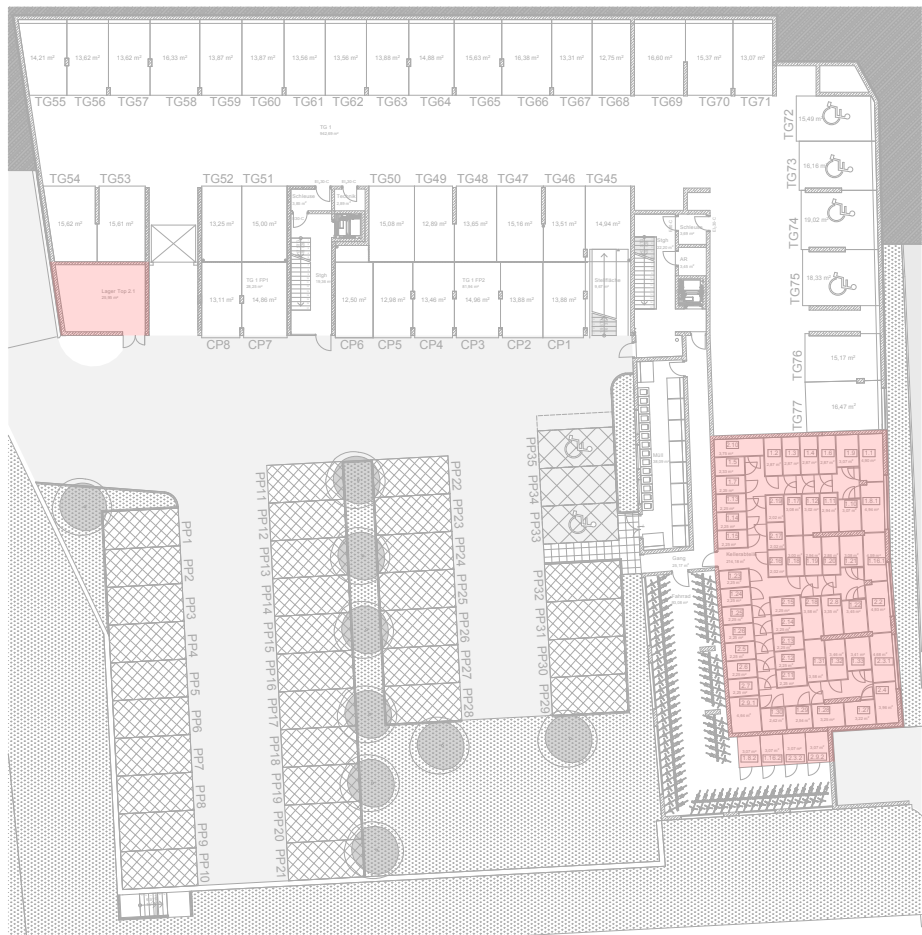

TG2

1:500

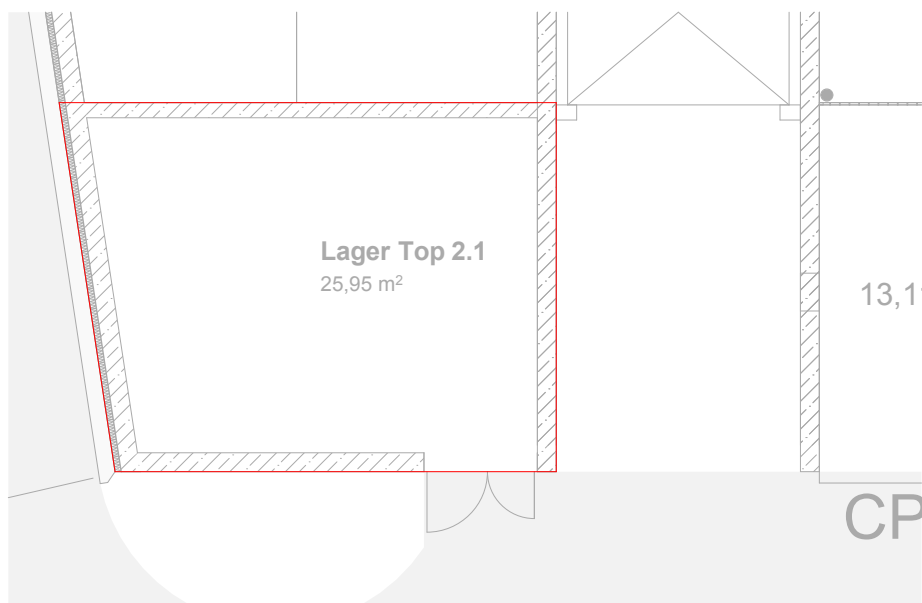

MO+US
 WIR ♥ IMMOBILIEN

TG 1 Kellerabteile

19091_Hauptstr. 143-145 Kalsdorf

Datum 10.05.2023

